

The way to clear the atomizer and case:

Dilute the detergent and pour it into the base, adding 45°C water to dissolve detergent. Soak for 10 minutes and gently scrub the surface with small brush until scale is removed. Wash the base with 1:1 of water and white vinegar or citric acid. Then clean the base and surface with water.

SAFETY INSTRUCTIONS:

When using electrical appliances, basic precautions should always be followed to reduce the risk of fire, electric shock, injury to person.

1. Pls don't repair or adjust the product base by yourself.
2. Pls don't try to replace the power cord when it is broken by yourself, you can ask our service department to do it.
3. Pls don't add any kind of additive into the water tank which was not recommended by ourself.
4. Please keep the detergent& humidifier away from the children
5. Any change or refitting without our confirmation will be dangerous.
6. Please immediately turn off the humidifier and unplug the power when there is an abnormal sound or smell, pls contact with the service department if you want to repair it.
7. Unplug the humidifier when moving or cleaning it.
8. Unplug the humidifier when not in use.
9. Please don't touch the water what is inside the case when it is in operation mode.
10. Please don't turn on the machine when there is no water.
11. please don't use the machine in high humidity atmosphere, such as shower room.
12. Please use the detergent which was produced or recommended by the manufacturer to clear the case and atomizer.
13. Please don't scrape or scratch the atomizer with hard particles.
14. Please prevent water run into the inner part of the base part when cleaning the machine.
15. Please use the low mode when low temperature or high humidity in case the mist couldn't run out smoothly.
16. Please duly handle the scrapped machine, don't discard it optionally.
17. In order to save the service life of the machine and avoid accident, please lay it in dry condition.
18. Place the humidifier on a flat, smooth, level surface.
19. Far away from the fire, such as the stove, avoid direct sunlight.
20. Please use the machine at the normal environment temperature.
21. The mist direction should be aimed away from walls, electric appliances furniture.

4

GENERAL TROUBLESHOOTING

DO NOT ATTEMPT TO REPAIR THE HUMIDIFIER BASE BY YOURSELF		
Symptoms	Reason analysis	Solutions
Indicator light doesn't work	The plug is not connected properly	Connect the plug correctly, turn on the power
	Power board disconnects with connecting line	Take off the base cover and, connect them correctly
	PCB is broken	Replace it with a new PCB
Indicator light in red color	Lacking water	Adding water
	The floating above the reed switch was blocked.	Twist the floating
Indicator light in green color no mist or mall mist	The protective shell of the floating ball hasn't been taken off	Take it off
	Has scale on the surface of the atomizer	Clean the atomizer
	Water is dirty or the water contains too much mineral substance	Replace it with clear water
Leaking water from the gap between the water tank and base part	The water is under low temperature	Using the water under 15~45°C
	Water tank was broken	Replace it with a new water tank
	Floating ball was broken	Replace it with a new floating ball
Leaking water from the bottom of the base part	Dirty floating ball or piston	Clean the floating ball and piston
	The base part was broken	Replace it with a new base part
It has mist in base part, but couldn't run out.	The screw which was used to fix the atomization board is not tight enough	Replace it with a new atomization board
	Fan was broken	Replace it with a new fan
	Air inlet was blocked	Take off the foam which is at the bottom of the base part
Abnormal smell	The Strainer mesh has dust or water	Clean the Strainer mesh
	New machine	Open the water tank and lay it open in a steady and cool place for 12 hours
Abnormal sound	Dirty water or water stored in the machine for a long time	Clean the water tank and add clear water
	Too much dust on the fan	Replace it with a new fan

Wall-mounted humidifier

Model no:HQ-JS853

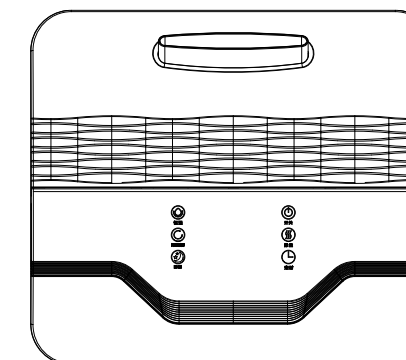

Ultrasonic Humidifier
Model : HQ-JS2315

TECHNICAL PARAMETERS:

Model no. : HQ-JS853	Tank capacity : 5L
Voltage : 100V-240V~	Noise : ≤ 46dB(A)
Frequency : 50Hz/60Hz	Net weight/Gross weight : 3.82kg/ 4.8kg
Rated input power : 100W	Unit size : 400×220×350mm
Mist capacity : 1800ml/h	

Features:

Automatic shut off upon empty tank
Adjustable mist volume
Constant humidity
Timer
Top filling
Night mode
Interval mist

The function of electronic model:

- ON/OFF, Plug in power cable. It is in standby mode and pop up white lights on the screen, Press power on button and the standby mode is canceled. humidifier start to work at high mode.
- Press this button to set timer from 1 to 12 hours.
- Mist adjustable button can change the mist volume from 1 to 3 levels.
- Constant humidity button : set humidity between 45%-95%. user press this button until it reaches 95%. press one more time to cancel settings. Set a certain value and the humidifier will work automatically. when the humidity in the room is achieving this value, it will stop working until humidity getting lower.
- Sleep mode : press this button and machine will enter sleep mode. The light on the screen will turn down. other functions are working as normal.

1

- It switches to several options : continuously spraying; sparing for 1 minute and stop for 1 minute; spraying for 1 minute and stop for 3 minutes; spraying for 1 minutes and stop for 5 minutes.

Structure diagram

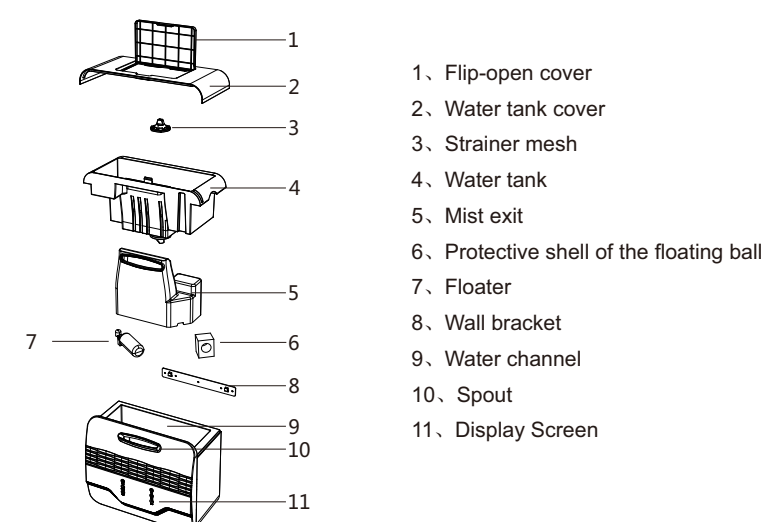

Operating instructions

For the initial use, please leave it at room temperature for half an hour. First, remove the protective shell of the floating ball before using it. Please power on it in dry and ventilated place.

Suitable working condition for humidifier is : 5~40°C. Humidity: less than 80%RH.

Use clean water with temperature lower than 40°C. (recommend purified water).

If it's not used for a long time, the tank should be cleaned. When cleaning the fan, please be sure to wipe water and do not bring water into case.

2

Operating steps:

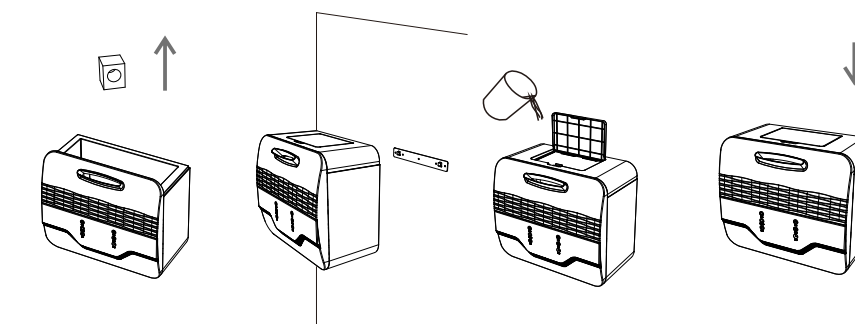

1. take off the protective shell of the floating ball before using , otherwise, the water in water tank couldn't run into the base channel.
2. Fix the bracket onto the wall, and install the humidifier onto the bracket.
3. Add liquid into the water tank, can add hypochlorous acid.
4. Install the tank cover onto the top side of the water tank.
5. Connect power cable, and touch the switch button (prohibited without water). Start to work in high mode.
6. Touch the mist volume button to adjust the mist volume.

Daily maintenance:

In some areas, the water quality is hard with high content of calcium and magnesium. In addition, bleaching powder is added into water in some districts. So when using humidifier, some of the calcium and magnesium spraying out. It turn out to be white powder in the surface of ultrasonic atomizer and water tank after it dried. This will impact the efficiency of humidifier.

The way to keep the humidifier clean:

Using purified water, recommend to wash atomizer, water tank, air net once a week. Frequently change the water in humidifier to keep it clean. If it is not used for a long time, do not leave any water in the water tank. Please clean and wipe each part of the machine before storing up.

3